



ACCESSORIES

Setscrew Ball Bearings

LUBRICANTS

DODGE ball bearings are factory lubricated with a lithium complex base lubricant. For applications where extreme ambient temperatures or speeds are anticipated or environmental considerations require a different lubricant, DODGE has a wide variety of lubricants available. Special lubricant options usually require set-up charges and premiums.

SEALS

The PROGUARD PLUS seal is a highly effective positive contact, land riding seal with flingers pressed on to each side of the inner ring offering added protection from wash down or extreme contamination. For high speeds or where seal drag would be an impediment, an all metallic labyrinth seal is available.

HIGH TEMPERATURE

DODGE high temperature bearings are designed to operate in temperatures from 225°F (108°C) to 400°F (205°C). The bearings have adjusted internal clearances, metallic labyrinth seals, high temperature retainers, heat stabilized outer rings, and lubricants to meet the temperature needs of the application. To insure proper replacement, the bearing is identified by a six digit part number etched on a stainless steel nameplate riveted to the housing. The part number identifies the specific feature of the bearing. High temperature bearings are factory assembled to order and are available at extra cost. Consult Dodge Engineering for application assistance at (864)284-5700 or fax (864) 281-2317.

AIR HANDLING

Industrial fans and blowers generally operate at high speeds with bearing requirements of long life and quiet operation. Dodge stocks SC, and SCM Air Handling Pillow Blocks and flange bearings that are specifically designed to meet the requirements of the air handling industry. These bearings are 100% noise tested, and have an air handling fit for long life and quiet operation. These bearings are recommended for fan and blower applications. Sizes and housing configurations not listed can be supplied on a made to order basis.

HOUSING MATERIAL

For extra corrosion resistance, a variety of housing finishes are available. Special materials include stainless steel or polymer housing, as an option. These coatings conform to U.S.D.A. and F.D.A. requirements. SC and SCM inserts can be supplied with a corrosion resistant coating on the inner and outer rings, stainless steel balls and set-screws, and nickel plated flingers as well as F.D.A. lubricant.

OTHER MODIFICATIONS

For applications requiring modifications not listed, we encourage you to contact our Customer Order Engineering Department at (864)284-5700 or fax (864)281-2317.

FEATURES/BENEFITS
PAGE B4-3

HOW TO ORDER/NOMENCLATURE
PAGE B4-5

SELECTION
PAGE B4-6

SELECTION/DIMENSIONS
PAGE B4-12

RELATED PRODUCTS



Setscrew Ball Bearings HIGH TEMPERATURE SC & SCM BALL BEARINGS

Series	Shaft Size	Pillow Blocks		2 Bolt Flanges		4 Bolt Flanges	
		Part No.	Description	Part No.	Description	Part No.	Description
204	1/2	@	P2B-SC-008L-HT	054843	F2B-SC-008L-HT	@	F4B-SC-008L-HT
	5/8	@	P2B-SC-010L-HT	057474	F2B-SC-010L-HT	067710	F4B-SC-010L-HT
	3/4	053670	P2B-SC-012-HT	052618	F2B-SC-012-HT	058263	F4B-SC-012-HT
	20mm	@	<i>P2B-SC-20M-HT</i>	074828	<i>F2B-SC-20M-HT</i>	@	<i>F4B-SC-20M-HT</i>
205	7/8	@	P2B-SC-014-HT	051906	F2B-SC-014-HT	@	F4B-SC-014-HT
	15/16	068088	P2B-SC-015-HT	056864	F2B-SC-015-HT	054190	F4B-SC-015-HT
	1	051513	P2B-SC-100-HT	052294	F2B-SC-100-HT	052015	F4B-SC-100-HT
	25mm	@	<i>P2B-SC-25M-HT</i>	059821	<i>F2B-SC-25M-HT</i>	@	<i>F4B-SC-25M-HT</i>
206	1	054782	P2B-SCM-100-HT	064880	F2B-SCM-100-HT	074530	F4B-SCM-100-HT
	1-1/8	@	P2B-SC-102-HT	062877	F2B-SC-102-HT	068290	F4B-SC-102-HT
	1-3/16	053169	P2B-SC-103-HT	052604	F2B-SC-103-HT	054419	F4B-SC-103-HT
	1-1/4	062829	P2B-SC-104S-HT	@	F2B-SC-104S-HT	049462	F4B-SC-104S-HT
206 (SCU)	30mm	@	<i>P2B-SC-30M-HT</i>	@	<i>F2B-SC-30M-HT</i>	054534	<i>F4B-SC-30M-HT</i>
	1-1/8	@	P2B-SCU-102-HT	-----	-----	-----	-----
	1-3/16	059737	P2B-SCU-103-HT	-----	-----	-----	-----
	1-1/4	057847	P2B-SCU-104S-HT	-----	-----	-----	-----
207	30mm	@	<i>P2B-SCU-30M-HT</i>	-----	-----	-----	-----
	1-3/16	054314	P2B-SCM-103-HT	@	F2B-SCM-103-HT	074223	F4B-SCM-103-HT
	30mm	@	P2B-SCM-30M-HT	059673	F2B-SCM-30M-HT	@	F4B-SCM-30M-HT
	1-1/4	058262	P2B-SC-104-HT	052311	F2B-SC-104-HT	051826	F4B-SC-104-HT
	1-3/8	@	P2B-SC-106-HT	@	F2B-SC-106-HT	068185	F4B-SC-106-HT
	1-7/16	050189	P2B-SC-107-HT	054300	F2B-SC-107-HT	052540	F4B-SC-107-HT
208	1-7/16	052531	P2B-SCB-107-HT	-----	-----	-----	-----
	35mm	@	<i>P2B-SC-35M-HT</i>	@	<i>F2B-SC-35M-HT</i>	s	<i>F4B-SC-35M-HT</i>
	1-7/16	054276	P2B-SCM-107-HT	@	F2B-SCM-107-HT	054342	F4B-SCM-107-HT
	1-1/2	057338	P2B-SC-108-HT	054203	F2B-SC-108-HT	051827	F4B-SC-108-HT
208	1-5/8	@	P2B-SC-110-HT	@	F2B-SC-110-HT	058194	F4B-SC-110-HT
	40mm	062572	<i>P2B-SC-40M-HT</i>	@	<i>F2B-SC-40M-HT</i>	@	<i>F4B-SC-40M-HT</i>

@ Assembled to order.

Bearing Reference Guide

ULTRA KLEEN

E-Z KLEEN

Extreme Duty

Setscrew Ball Bearing

GRIP TIGHT

D-LOK Ball Bearing

FEATURES/BENEFITS PAGE B4-3	HOW TO ORDER/NOMENCLATURE PAGE B4-5	SELECTION PAGE B4-6	ACCESSORIES PAGE B4-98
--------------------------------	--	------------------------	---------------------------



RELATED PRODUCTS

Setscrew Ball Bearings HIGH TEMPERATURE SC & SCM BALL BEARINGS

Series	Shaft Size	Pillow Blocks		2 Bolt Flanges		4 Bolt Flanges	
		Part No.	Description	Part No.	Description	Part No.	Description
209	1-1/2	058380	P2B-SCM-108-HT	054203	F2B-SCM-108-HT	064557	F4B-SCM-108-HT
	1-5/8	@	P2B-SC-110L-HT	@	F2B-SC-110L-HT	@	F4B-SC-110L-HT
	1-11/16	053563	P2B-SC-111-HT	@	F2B-SC-111-HT	057212	F4B-SC-111-HT
	1-11/16	058619	P2B-SCB-111-HT	-----	-----	-----	-----
	1-3/4	062676	P2B-SC-112-HT	062157	F2B-SC-112-HT	051825	F4B-SC-112-HT
	45mm	@	P2B-SC-45M-HT	@	F2B-SC-45M-HT	@	F4B-SC-45M-HT
210	1-11/16	054315	P2B-SCM-111-HT	@	F2B-SCM-111-HT	054593	F4B-SCM-111-HT
	1-3/4	@	P2B-SCM-112-HT	057114	F2B-SCM-112-HT	057368	F4B-SCM-112-HT
	1-15/16	052047	P2B-SC-115-HT	073280	F2B-SC-115-HT	052048	F4B-SC-115-HT
	1-15/16	052532	P2B-SCB-115-HT	-----	-----	-----	-----
	2	058183	P2B-SC-200-HT	062309	F2B-SC-200-HT	057132	F4B-SC-200-HT
	50mm	@	P2B-SC-50M-HT	062779	F2B-SC-50M-HT	068066	F4B-SC-50M-HT
211	1-15/16	052276	P2B-SCM-115-HT	@	F2B-SCM-115-HT	057363	F4B-SCM-115-HT
	2	054934	P2B-SCM-200-HT	@	F2B-SCM-200-HT	054065	F4B-SCM-200-HT
	2-3/16	053955	P2B-SC-203-HT	059954	F2B-SC-203-HT	058852	F4B-SC-203-HT
	2-1/4	073065	P2B-SC-204-HT	@	F2B-SC-204-HT	054918	F4B-SC-204-HT
	55mm	@	P2B-SC-55M-HT	076558	F2B-SC-55M-HT	049894	F4B-SC-55M-HT
212	2-3/16	054412	P2B-SCM-203-HT	@	F2B-SCM-203-HT	073772	F4B-SCM-203-HT
	2-1/4	068266	P2B-SCM-204-HT	@	F2B-SCM-204-HT	067830	F4B-SCM-204-HT
	2-7/16	059614	P2B-SC-207-HT	@	F2B-SC-207-HT	057487	F4B-SC-207-HT
	60mm	057800	P2B-SC-60M-HT	057800	F2B-SC-60M-HT	057801	F4B-SC-60M-HT
214	2-7/16	054316	P2B-SCM-207-HT	-----	-----	054917	F4B-SCM-207-HT
	2-1/2	073006	P2B-SCM-208-HT	-----	-----	056630	F4B-SCM-208-HT
	2-11/16	067774	P2B-SC-211-HT	-----	-----	065700	F4B-SC-211-HT
	70mm	@	P2B-SC-70M-HT	-----	-----	@	F4B-SC-70M-HT
215	2-15/16	056588	P2B-SC-215-HT	-----	-----	052550	F4B-SC-215-HT
	75mm	@	P2B-SC-75M-HT	-----	-----	074237	F4B-SC-75M-HT
216	2-15/16	054556	P2B-SCM-215-HT	-----	-----	052478	F4B-SCM-215-HT
	3	@	P2B-SCM-300-HT	-----	-----	059696	F4B-SCM-300-HT
	75mm	@	P2B-SCM-75M-HT	-----	-----	062182	F4B-SCM-75M-HT
218	3-7/16	049991	P2B-SCM-307-HT	-----	-----	057708	F4B-SCM-307-HT
	3-1/2	@	P2B-SCM-308-HT	-----	-----	058633	F4B-SCM-308-HT

@ Assembled to order.

FEATURES/BENEFITS
PAGE B4-3

HOW TO ORDER/NOMENCLATURE
PAGE B4-5

SELECTION
PAGE B4-6

ACCESSORIES
PAGE B4-98



RELATED PRODUCTS

Setscrew Ball Bearings HIGH TEMPERATURE SC & SCM BALL BEARINGS

Series	Shaft Size	Tapped Base Pillow Blocks		Flanged Bracket	
		Part Number	Description	Part Number	Description
204	3/4	059636	TB-SC-012-HT	@	FB-SC-012-HT
205	1	057906	TB-SC-100-HT	@	FB-SC-100-HT
207	1-1/4	@	TB-SC-104-HT	056578	FB-SC-104-HT
211	2-3/16	050555	TB-SC-203-HT		

Series	Shaft Size	Non Expansion Pillow Blocks		Expansion Pillow Blocks	
		Part Number	Description	Part Number	Description
206	1-3/16	-----	-----	054063	P2B-SCH-103-EHT
207	1-7/16	053894	P2B-SCH-107-HT	053895	P2B-SCH-107-EHT

Series	Shaft Size	Piloted Flanges	
		Part Number	Description
206	1	058652	FC-SCM-100-HT
208	1-1/2	053871	FC-SC-108-HT
	1-1/2	057683	FC-SCM-108-HT
211	1-15/16	058915	FC-SCM-115-HT
	2-1/4	058233	FC-SC-204-HT
212	2-7/16	058738	FC-SC-207-HT
	55mm	054837	FC-SCM-55M-HT
216	2-15/16	054831	FC-SCM-215-HT
	3	056911	FC-SCM-300-HT
218	3-7/16	068239	FC-SCM-307-HT

Series	Shaft Size	Wide Slot Take-up		Narrow Slot Take-up	
		Part Number	Description	Part Number	Description
210	1-15/16	057265	WSTU-SC-115-HT	054580	NSTU-SC-115-HT
211	55mm	049893	WSTU-SC-55M-HT	@	NSTU-SC-55M-HT
	1-15/16	049891	WSTU-SCM-115-HT	@	NSTU-SCM-115-HT
212	2-7/16	057839	WSTU-SC-207-HT	064237	NSTU-SC-207-HT
214	2-7/16	049811	WSTU-SCM-207-HT	@	-----
215	2-15/16	059844	WSTU-SC-215-HT	@	-----

@ Assembl to order.

FEATURES/BENEFITS PAGE B4-3	HOW TO ORDER/NOMENCLATURE PAGE B4-5	SELECTION PAGE B4-6	ACCESSORIES PAGE B4-98
--------------------------------	--	------------------------	---------------------------



RELATED PRODUCTS

DODGE Ball Bearing End Covers*

BALL BEARING END COVERS FOR MOUNTED UNITS 214 SERIES & LARGER

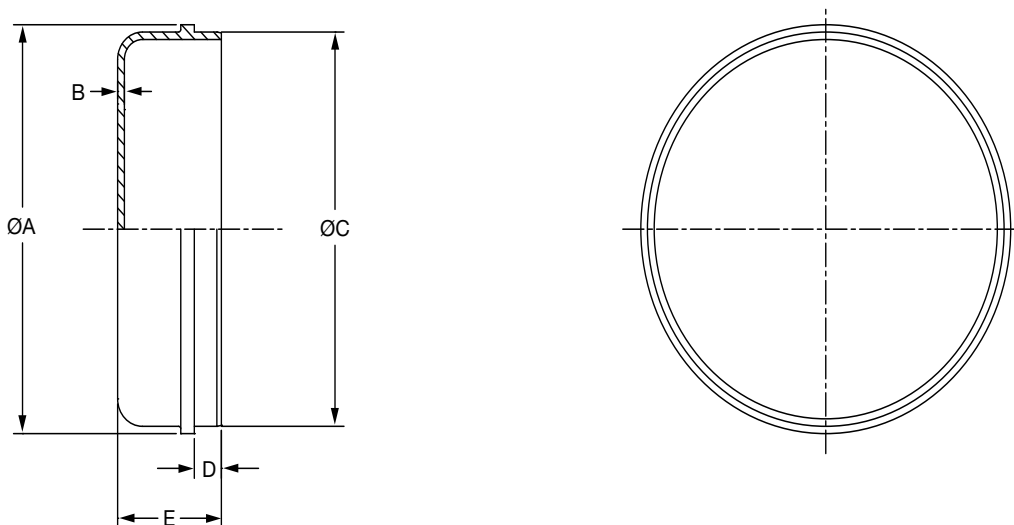

Series	Shaft Size		Part Number	Description
	SC, VSC, DL, SXR, SXV, SCH-E, SXRH-E, DLH-E	SC, VSC, DL, SCM & DLM		
214	2-1/2 & 2-11/16 70mm	2-7/16 & 2-1/2 65mm	480037	EC-080
215	2-15/16 75mm	2-11/16 70mm	480455	EC-090
216	----- -----	2-15/16 & 3 75mm	480456	EC-100
218	----- -----	3-7/16 & 3-1/2 85mm	480457	EC-110

Series	Shaft Size		Weight lbs gm	A	B	C	D	E
	SC, VSC, DL, SXR, SXV, SCHSXRH, DLH	SC, VSC, DL, SCM & DLM						
214	2-1/2 & 2-11/16 70mm	2-7/16 & 2-1/2 65mm	0.33 151	4-15/16 125.4	3/32 2.4	4.741/4.737 120.4/120.3	3/16 4.8	1-13/32 35.7
215	2-15/16 75mm	2-11/16 70mm	0.36 164	5-1/8 130.2	3/32 2.4	4.944/4.940 125.6/125.5	3/8 9.5	1-7/16 36.5
216	----- -----	2-15/16 & 3 75mm	0.44 201.00	5-9/16 141.3	3/32 2.4	5.350/5.346 135.9/135.8	9/32 7.1	1-7/16 36.5
218	----- -----	3-7/16 & 3-1/2 85mm	0.57 257	6-5/16 160.3	3/32 2.4	6.100/6.096 154.9/154.8	3/8 9.5	1-9/16 39.7

NOTE: WILL NOT WORK WITH PILLOW-BLOCK HOUSINGS

FEATURES/BENEFITS PAGE B4-3	HOW TO ORDER/NOMENCLATURE PAGE B4-5	SELECTION PAGE B4-6	ACCESSORIES PAGE B4-98
--------------------------------	--	------------------------	---------------------------

Bearing Reference Guide

ULTRA KLEEN

E-Z KLEEN

Extreme Duty

Setscrew Ball Bearing

GRIP TIGHT

D-LOK Ball Bearing